

KINGS A D V E N T U R E

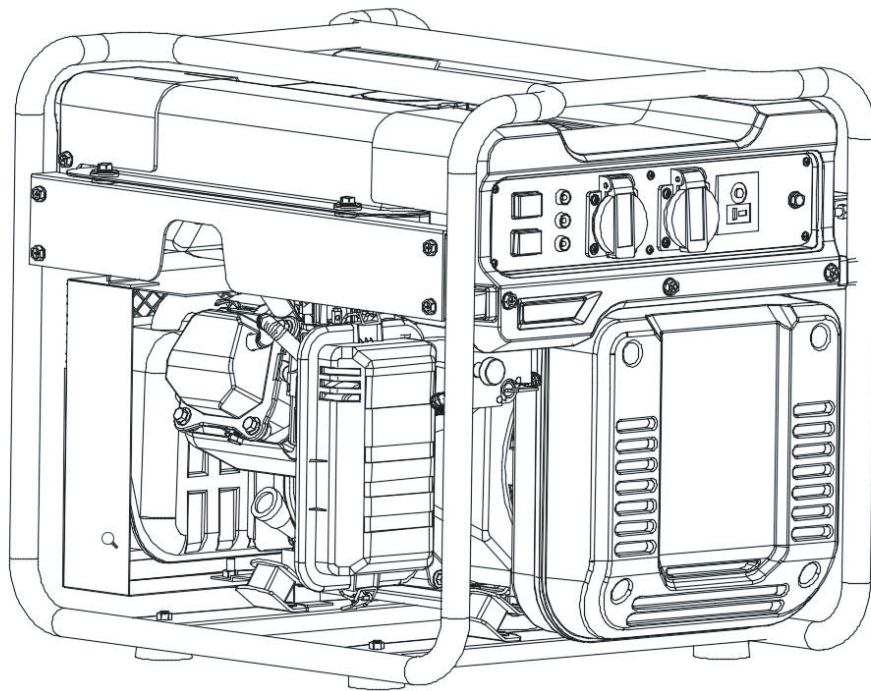

Petrol Inverter Generator USER MANUAL

**PLEASE READ AND UNDERSTAND THIS MANUAL COMPLETELY
BEFORE OPERATING THE GENERATOR.**

**NOTE: THE GENERATOR HAS BEEN SHIPPED
WITHOUT ENGINE OIL. FILL IT WITH THE
CORRECT OIL OR IT WILL NOT START*****

CONTENTS

1. SAFETY INFORMATION	2
2. CONTROL FUNCTION.....	3
3. PRE-OPERATION CHECK.....	5
4. OPERATION	6
5. PERIODIC MAINTENANCE	9
6. TROUBLESHOOTING.....	12
7. STORAGE.....	13
8. SPECIFICATIONS	14
9. WIRING DIAGRAM	15
10. WARRANTY	17

WARNING!

PLEASE READ AND UNDERSTAND THIS MANUAL COMPLETELY BEFORE OPERATING THE GENERATOR.

SAFETY INFORMATION

1) EXHAUST FUMES ARE POISONOUS

- Never operate the engine in a closed area or it may cause unconsciousness and death within a short time. Operate the engine in a well ventilated area.

2) FUEL IS HIGHLY FLAMMABLE AND POISONOUS

- Always turn off the engine when refuelling
- Never refuel while smoking or in the vicinity of an open flame.
- Take care not to spill any fuel on the engine or muffler when refuelling.
- If you swallow any fuel, inhale fuel vapour, or allow any to get in your eyes, see your doctor immediately. If any fuel spills on your skin or clothing, immediately wash with soap and water and change your clothes.
- When operating or transporting the machine, be sure it is kept upright. If it tilts, fuel may leak from the carburettor or fuel tank.

3) ENGINE AND MUFFLER MAY BE HOT

- Place the machine in a place where pedestrians or children are not likely to touch the machine.
- Avoid placing any flammable materials near the exhaust outlet during operation.
- Keep the machine at least 1 m (3 ft) from buildings or other equipment, or the engine may overheat.
- Avoid operating the engine with a dust cover.
- Be sure to carry the generator only by its carrying handle.
- Put the machine on the flat ground, so it can eliminate heat freely.

4) ELECTRIC SHOCK PREVENTION

- Never operate the engine in rain or snow.
- Never touch the machine with wet hands or electrical shock will occur.
- Be sure to ground (earth) the generator.

NOTE:

Use ground (earth) lead of sufficient current capacity.

Diameter: 0.12mm (0.005 in)/ampere

EX: 10 Ampere --1.2mm (0.055 in)

5) CONNECTION NOTES

- Avoid connecting the generator to a commercial power outlet.
- Avoid connecting the generator in parallel with any other generator.

2. CONTROL FUNCTION

- | | | |
|---------------------------|--------------------|--------------------|
| (1) Control Panel | (2) Choke Knob | (3) Inverter Cover |
| (4) Fuel Switch (Petcock) | (5) Recoil Starter | (6) Muffler |
| (7) Muffler Cover | (8) Fuel Tank | (9) Fuel Tank Cap |
| (10) Fuel Guage | (11) Air Filter | |

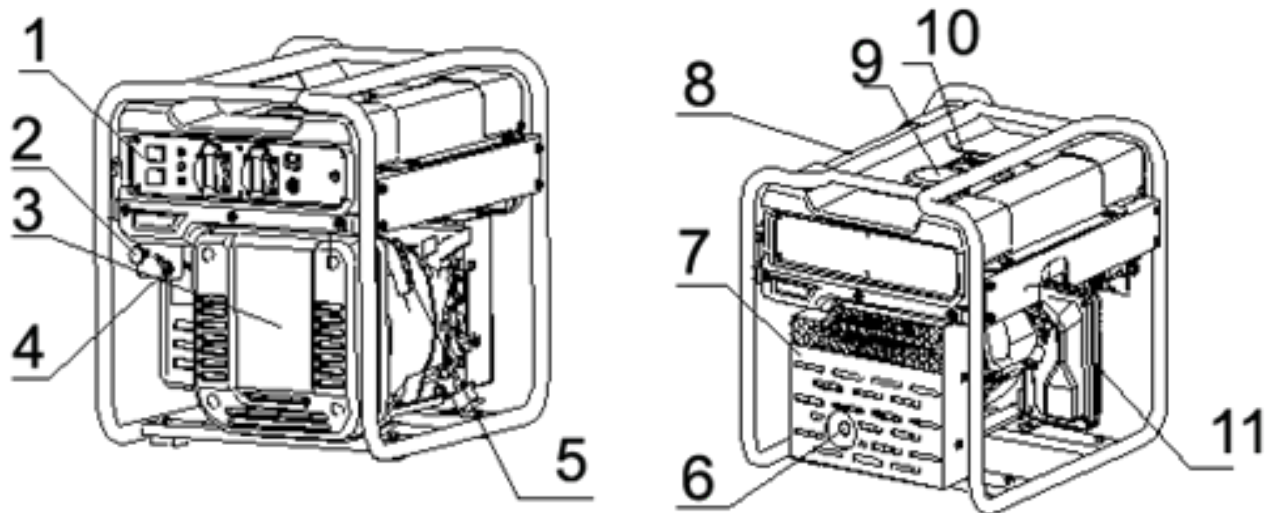

2. CONTROL FUNCTION (CONTD)

- | | | |
|--------------------------------|----------------------------|------------------------------------|
| (1) Oil Warning Light (Yellow) | (2) AC Pilot Light (Green) | (3) Overload Indicator Light (Red) |
| (4) Economy Switch | (5) ON/STOP Switch (Red) | (6) DC Receptacle |
| (7) Ground (earth) Terminal | (8) DC Protector | (9) AC Receptacle |

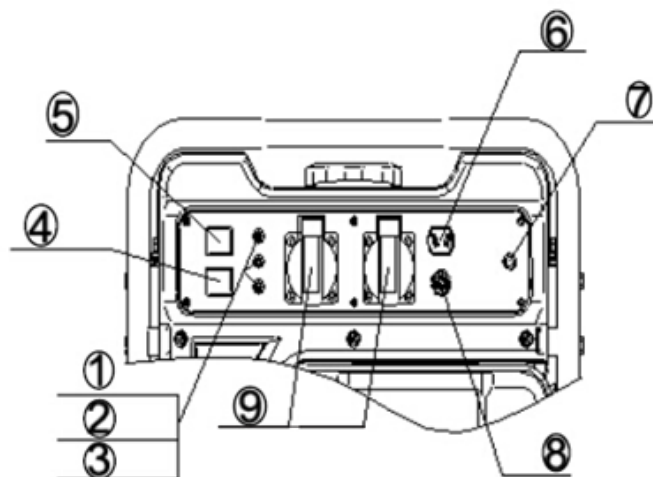

1) OIL WARNING SYSTEM

- When the oil level falls below the lower level, the engine stops automatically. Unless you refill with oil, the engine will not start again.

2) ENGINE SWITCH

- The engine switch controls the ignition system.
- Ignition circuit is switched on. The engine can be started.

“ON” (run)

- Ignition circuit is switched off. The engine will not run.

“OFF” (stop)

3) ECONOMY CONTROL SWITCH

- When the economy control switch (ECS) is turned “ON”, the economy control unit controls the engine speed according to the connected load. The results are better fuel consumption and less noise.
- When the economy control switch (ECS) is turned "OFF", the engine runs at 4500RPM regardless of whether a load is connected or not.

Note: The ECS must be turned "OFF" for electrical devices that require a large starting current.

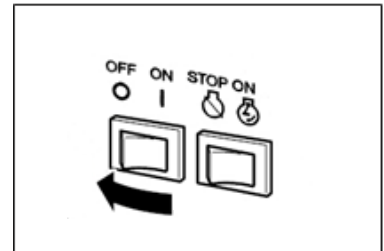
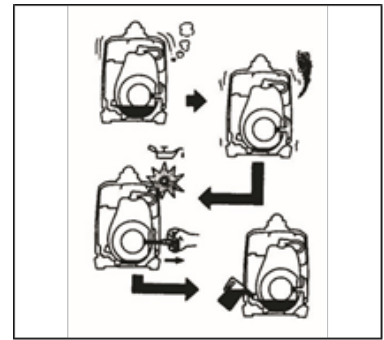

CAUTION:

Reduce the load to within the specified generator rated output if the DC circuit protector turns the engine off.

6) FUEL COCK

- The fuel cock is used to supply fuel from the tank to the carburettor.

NOTE:

Turn fuel cock to the 'off' position while transporting generator

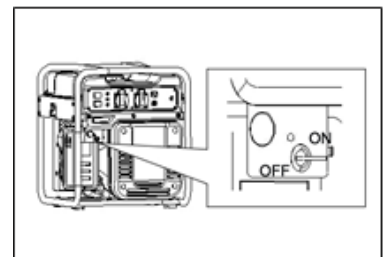

3. PRE-OPERATION CHECK

NOTE:

Pre-operation checks should be made each time the generator is used

1) CHECK ENGINE FUEL

- Make sure there is sufficient fuel in the tank.
- If fuel is low, refill with unleaded automotive gasoline.
- Be sure to use the fuel filter screen.
- Recommended fuel: Unleaded Petrol (DO NOT use ethanol or high octane fuels).
- Fuel tank capacity: 13 litres.

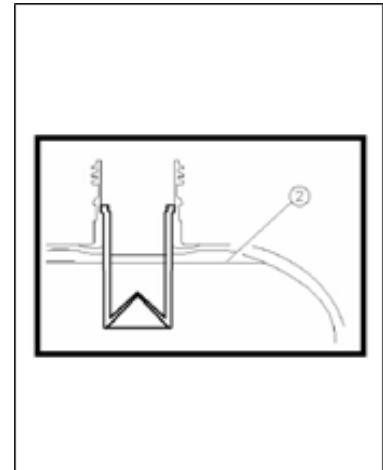

WARNING:

- Do not refill tank while engine is running or hot.
- Close fuel cock before refueling with fuel.
- Be careful not to admit dust, dirt, water or other foreign objects into fuel.
- Do not overfill, a minimum of 0.64CM's from the fuel cap is required to account for fuel expansion (2).
- Wipe off spilt fuel thoroughly before starting engine.
- Keep open flames away.

2) CHECK ENGINE OIL

- Make sure the engine oil is at the upper level of the oil filler hole. Add oil as necessary.
- Remove oil filler cap and check the engine oil level.
- If oil level is below the lower level line, refill with suitable oil to upper level line. Do not screw in the oil filler cap when checking oil level.
- Change oil if contaminated.
- Fill oil until visible at the upper level of oil filler hole (Approx. 450ML)

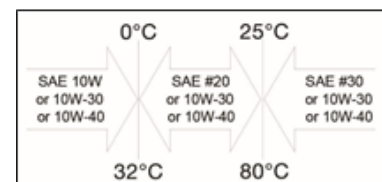

Recommended engine oil: **SAE10 W30**

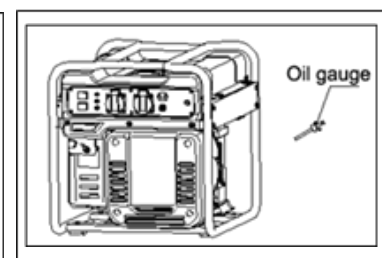
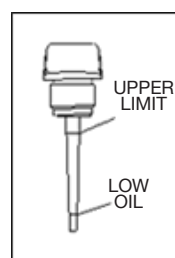

3) GROUND (Earth)

- Make sure to ground (earth) the generator.

4. OPERATION

NOTE:

The generator has been shipped without engine oil. Fill with oil or it will not start.

Do not tilt the generator when adding engine oil. This could result in overfilling and damage to the engine.

1) STARTING THE ENGINE

NOTE: BEFORE STARTING THE ENGINE, DO NOT CONNECT THE ELECTRIC APPARATUS.

1. Turn the fuel cock lever to the "ON" position.
2. Turn the engine switch to the "ON" position.
3. Turn the Economy Switch to the "OFF" position.
4. Check there is adequate fuel in the tank.
5. Pull the choke knob until it is fully extended. Not necessary if the engine is warm.
6. Pull the starter handle slowly until resistance is felt. This is the "Compression" point. Return the handle to its original position and pull swiftly. Do not fully pull out the rope. After starting, allow the starter handle to return to its original position while still holding the frame. Grasp the frame firmly to prevent the generator from falling over when pulling the recoil starter.
7. Warm up the engine.
8. Push the choke knob back into the generator to return it to its normal position.
9. Warm up the engine without a load for a few minutes.

2) USING ELECTRIC POWER

A) AC APPLICATION

1. Check the AC pilot lamp for proper voltage.
2. Turn off the Switch(es) of the electrical appliance(s) before connecting to the generator.
3. Insert the plug(s) of the electrical appliance(s) into the receptacle.

CAUTION:

- Be sure the electric apparatus is turned off before plugging in.
- Be sure the total load is within generator rated output.
- Be sure the socket load current is within socket rated current.
- The economy control switch must be turned to "OFF" when using electric devices that require a large starting current, such as a compressor or a submersible pump.

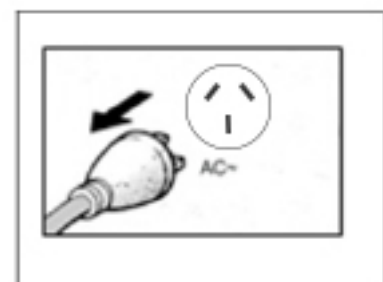
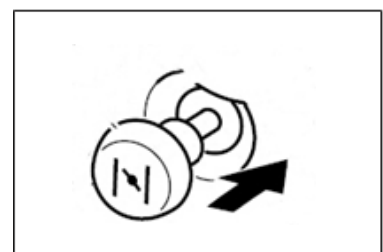
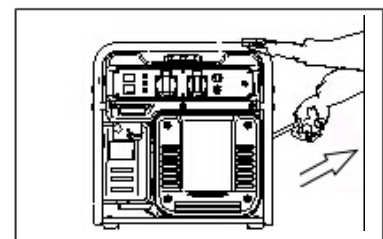
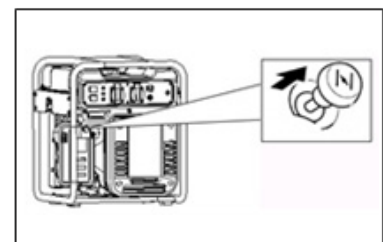
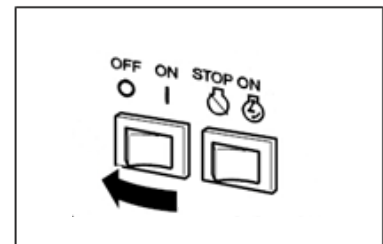
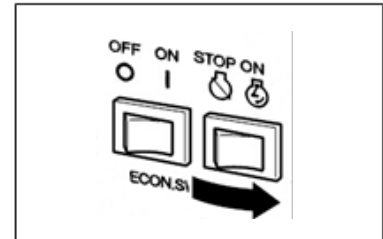
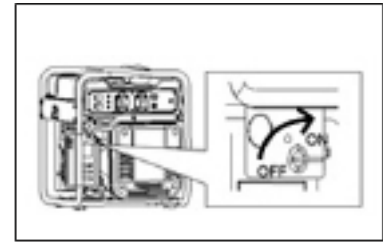

B) OVERLOAD INDICATOR LIGHT

The overload indicator light comes on when an overload of a connected electrical device is detected, the inverter unit overheats, or the AC output voltage rises. The electronic breaker will then activate, stopping power to the generator in order to protect the generator and any connected electric devices. The output pilot light (green) will flicker and the overload indicator light (red) will turn on, then the engine will stop running. If so please follow these steps:

4. Turn off any connected electric devices and stop the engine
5. Reduce the total wattage of connected electric devices within the application range.
6. After checking, restart the engine.

CAUTION:

- The generator AC output automatically resets when the engine is stopped and then restarted.
- The overload indicator light may come on for a few seconds at first when using electric devices that require a large starting current, such as a compressor or a submersible pump. However, this is not a malfunction.

C) DC APPLICATION (option)

This usage is applicable to 12V battery charging only.

- Charging instruction for battery
 - Disconnect the leads for the battery.
 - Make the battery fluid filler cap loose fully.
 - Fill distilled water to the upper limit, if the battery fluid is low level.
 - Measure the specific gravity for the battery fluid by using the hydrometer, and calculate the charging time in according with the table shown on right side.
 - The specific gravity for the fully charged battery shall be within 1.26 to 1.28.
- Connect the DC output socket and the battery terminals using the charging leads. The leads shall be connected making sure of the (+) and (-) polarity.
- The DC circuit protector is to be set to "ON" after confirming the connection, if the protector is in "OFF" position.

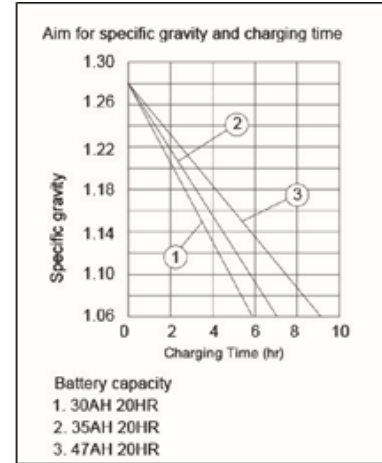

CAUTION:

- Be sure the economy control switch is turned "OFF" while charging the battery.

3) STOPPING THE ENGINE

- Turn off the power switch of the electric apparatus or disconnect any electric devices.
- Turn the engine switch to "STOP" position.
- Turn the fuel cock lever to "OFF".

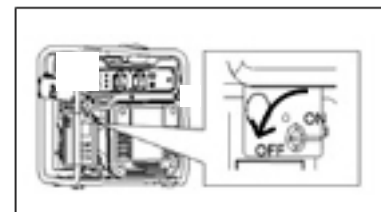
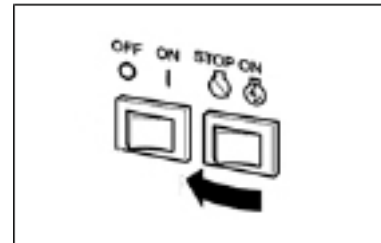

5. PERIODIC MAINTENANCE

1) MAINTENANCE CHART

Regular maintenance is important for the best performance and safe operation of your generator.

Item	Remarks	Pre-operation check (daily)	Initial 1 months or 20 Hr	Every 3 months or 50Hr	Every 6 months or 100Hr	Every 12 months or 300Hr
Spark Plug	Check condition adjust gap and clean. Replace if necessary.			●		
Engine Oil	Check oil level	●				
	Replace		●		●	
Oil filter	Clean oil filter				●	
Air Filter	Clean. Replace if necessary.			●		
Fuel Filter	Clean fuel cock filter. Replace if necessary				●	
Choke	Check choke operation	●				
Valve Clearance	Check and adjust when engine is cold.					●
Fuel Line	Check fuel hose for crack or damage. Replace if necessary.	●				
Exhaust System	Check for leakage. Retighten or replace gasket if necessary	●				
	Check muffler screen. Clean / replace if necessary.					●
Carburetor	Check choke operation	●				
Starting system	Check recoil starter operation.	●				
Idle speed	Check and adjust engine idle speed					●
Fittings / Fasteners	Check all fittings and fasteners correct if necessary.				●	
Crankcase breather	Check breather hose for cracks or damage. Replace if necessary					●
Generator	Check the pilot light comes on	●				

5. PERIODIC MAINTENANCE (CONTD)

2) ENGINE OIL REPLACEMENT

1. Place the machine on a level surface and warm up the engine for several minutes. Then stop the engine and turn the fuel cock knob to "OFF".
2. Remove the oil filler cap (1).
3. Place an oil pan under the engine. Tilt the generator to drain the oil completely
4. Place the generator on a level surface.
5. Re-install the screw
6. Add engine oil to the upper level.
7. Install the oil filler cap
8. Recommended engine oil:
SAE10 W30

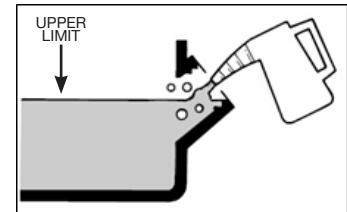
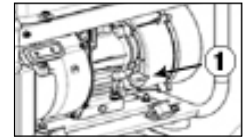

CAUTION:

- Be sure no foreign material enters the crankcase.
- Do not tilt the generator when adding engine oil. This could result in overfilling and damage to the engine
- Clean the oil filter every other 100hr.

3) AIR FILTER

Maintaining an air cleaner in proper condition is very important. Dirt induced through improperly installed, improperly serviced, or inadequate elements damages and wears out engines. Keep the element clean at all times

1. Remove the air filter cover and element.
2. Wash the element in solvent and dry.
3. Oil the element with foam air filter oil and squeeze out any excess. The element should be wet but not dripping.
4. Insert the element into the air filter.
5. Install the air filter cover

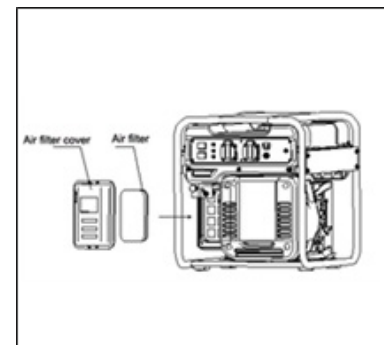

CAUTION:

- The engine should never run without the element; excessive piston and/or cylinder wear may result.

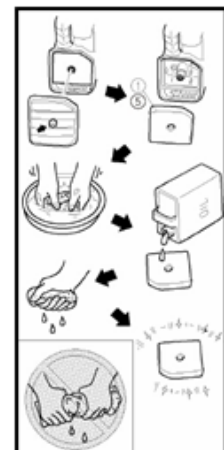

5. PERIODIC MAINTENANCE (CONTD)

4) CLEANING AND ADJUSTING SPARK PLUG

1. Remove the ignition lead plug (1).
2. Insert spark plug socket onto the spark plug.
3. Turn counter clockwise to remove the spark plug.
4. Check for discoloration and remove any excess carbon. The porcelain insulator around the centre electrode of the spark plug should be a medium to light tan colour.
5. Ensure to use the following spark plug type and gap (a).
Spark Plug: E6TC/E6RTC (Torch)
Spark Plug Gap: 0.6-0.7mm (0.024-0.028in)

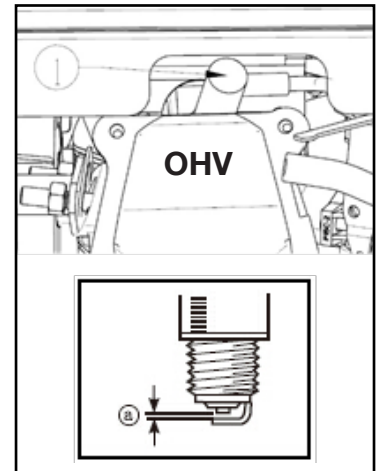

5) FUEL TANK FILTER

1. Remove the fuel tank cap and filter.
2. Clean the filter with solvent. If damaged, replace.
3. Wipe the filter and insert it.

CAUTION:

- Be sure the tank cap is tightened securely.

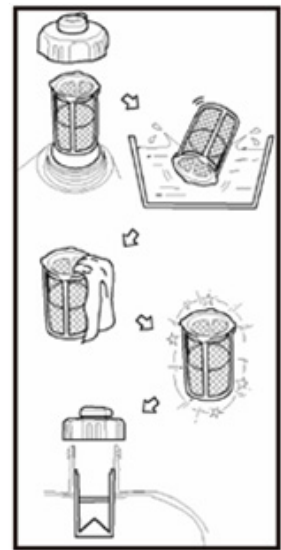

6) MUFFLER SCREEN

CAUTION:

- The engine and muffler will be very hot after the engine has been running.
- Avoid touching the engine and muffler while they are still hot with any part of your body or clothing during inspection or repair.

1. Remove the muffler screen.
2. Use the flathead screw driver to pry the spark arrester out from the muffler
3. Remove the carbon deposits on the muffler screen and spark arrester using a wire brush.
4. Install the spark arrester and muffler screen.
5. Install the cover

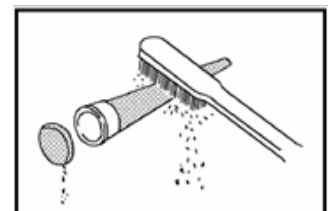

6. TROUBLE SHOOTING

1) ENGINE WON'T START

1. Fuel systems

- No fuel supplied to combustion chamber.
- No fuel in tank... Supply fuel.
- Fuel in tank... fuel cock knob to "ON".
- Clogged fuel line... Flush fuel lines.
- Clogged carburettor... Clean carburettor.

2. Engine oil system

- Insufficient
- Oil level is low... Add engine oil.

3. Electrical systems

- Poor spark
- Spark plug dirty with carbon or wet... Remove carbon or wipe spark plug dry.
- Faulty ignition system... Consult dealer.

4. Compression insufficient

- Worn out piston and cylinder... Consult dealer.

2) GENERATOR WON'T PRODUCE POWER

- If Safety device (AC) is switched to "OFF" ...Stop the engine, then restart.
- If Safety device (DC) is switched to "OFF"...Press to reset the DC protector.

7. STORAGE

Long term storage of your machine will require some preventive procedures to guard against deterioration.

1) DRAIN THE FUEL

1. Remove the fuel tank cap, drain the fuel from the fuel tank
2. Drain fuel from the carburettor by loosening the drain screw.

2) ENGINE

1. Remove the spark plug, pour in about one tablespoon of SAE 10W30 or 20W40 motor oil into the spark plug hole and reinstall the spark plug.
2. Use the recoil starter to turn the engine over several times (with ignition off).
3. Pull the recoil starter until you feel compression.
4. Stop pulling.
5. Clean exterior of the generator and apply a rust inhibitor.
6. Store the generator in a dry, well-ventilated place, with the cover place over it.
7. The generator must remain in a vertical position.

8. SPECIFICATIONS

MODEL		3500IG
GENERATOR	Type	Inverter Generator
	AC Voltage	240V
	Frequency	50Hz
	Max. Output	3.5kW
	Rated Output	3.2 kW
	Power Factor	1.0
	DC Output	12V/8.0A (Option)
ENGINE	Model	QL170F
	Type	Air-cooled, 4 stroke, OHC, Petrol Engine
	Bore×Stroke	70mm × 55mm
	Displacement	212cc
	Max. Output	3.5 kW / 3800rpm
	Fuel	Unleaded petrol (91 octane – no ethanol)
	Fuel tank Capacity	13 liters
	Rated Continuous Operation (70% of rated load)	10hrs
	Lubricating oil	SAE 10W30
	Lubricating oil Capacity	0.45 liters
	Starting System	Recoil Starter
	Ignition system	C.D.I. (Capacitor Discharge Ignition)
	Spark Plug: Type	E6TC/E6RTC (Torch)
DIMENSION	Net dimension	520mm × 440mm × 470mm (L×W×H)
	Overall dimension	560mm × 480mm × 520mm (L×W×H)
	Net Weight	35.5 Kg
	Gross Weight	38 Kg

* Specifications subject to change without prior notice.

8. WIRING DIAGRAM

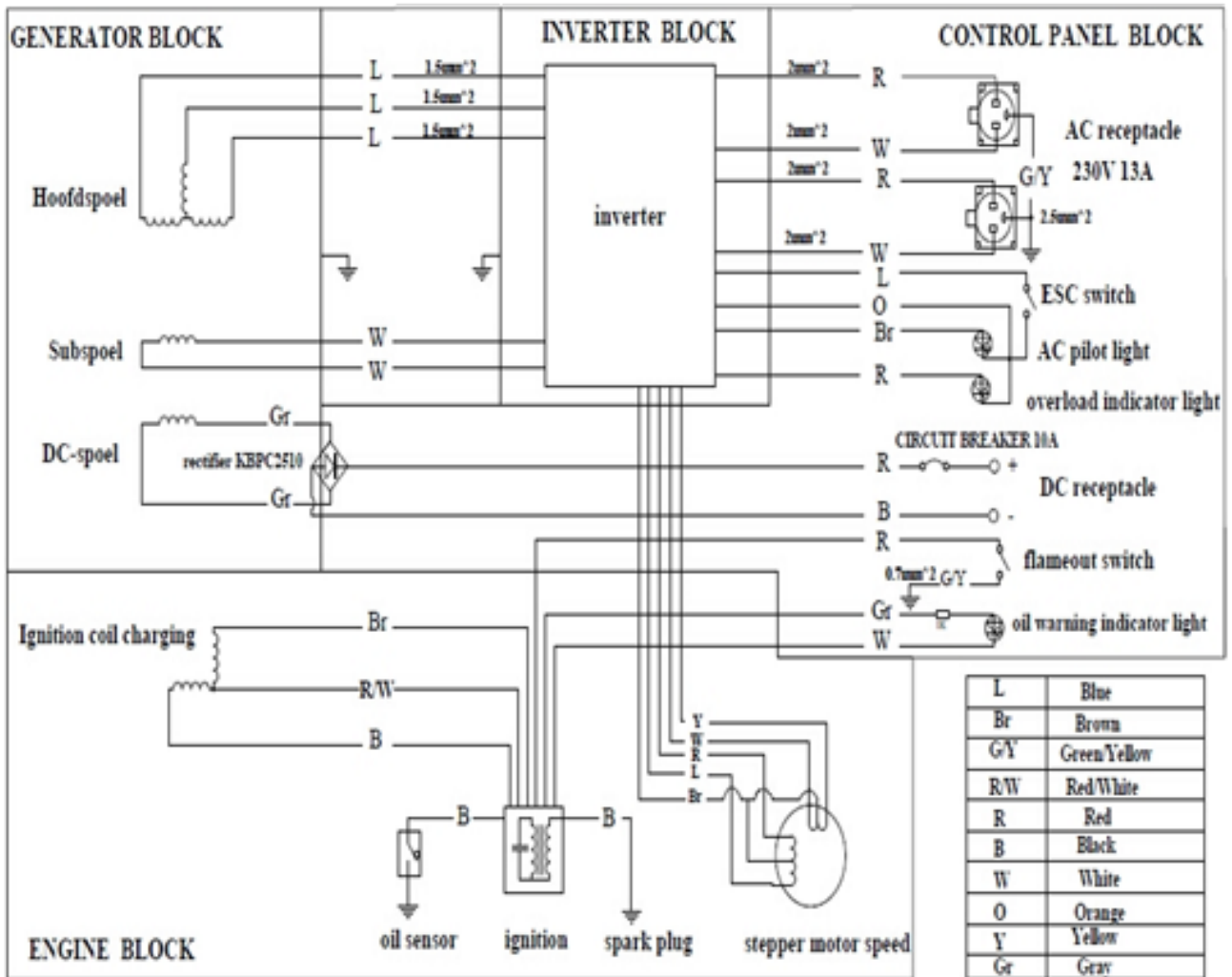



**WARNING: THE OUTPUT OF THIS GENERATOR
CAN CAUSE INJURY OR DEATH.**

DO NOT operate this generator near water or in damp/ wet conditions.

Avoid operating this generator with damp or wet hands.

This generator is not weatherproof.

Ethanol or high octane fuels should not be used in this generator.

CAUTION generator has hot surfaces during and after use.

NEVER connect this generator to a domestic or commercial power supply.

THIS GENERATOR SHOULD NOT BE CONNECTED TO ANY FIXED ELECTRICAL INSTALLATION.

Switch off engine when refueling.

NEVER operate generator while smoking or intoxicated.

Misuse of generator may result in a potential danger of an explosion of fire.

This generator is **NOT** designed to be operated by persons with reduced mental and physical capabilities or children.

Appliances **MUST** be **OFF** before connecting to this generator.

NEVER START or stop this generator with extension leads, appliances or loads connected.

ALWAYS disconnect extension leads, appliances or loads before stopping this generator.

AVOID breathing in fuel or exhaust fumes.

Ensure when not in use or being transported the fuel cock is in the off position and the fuel filler breather is closed.

This generator must not be laid on its side – always mount upright with the rubber feet on the ground.

Check engine oil level before each start.

**DANGER: Do not use indoors or poorly ventilated conditions.
Carbon monoxide fumes from the exhaust can kill in minutes.**

WARRANTY

24 MONTH LIMITED

WARRANTY PERIOD:

Full 24 month warranty from date of purchase against all manufacturing defects.

WHAT DOES THE WARRANTY COVER?

Under normal usage conditions, this warranty covers:

- a. Any defect in design or manufacture which results in the product failing to perform substantially as described in authorised advertising or literature.
- b. We will either repair or replace the product at our discretion providing that the fault is found to have been caused by a design or manufacturing defect and not misuse or tampering.

Our goods come with guarantees that cannot be excluded under the Australian Consumer Law. You are entitled to a replacement or refund for a major failure and for compensation for any other reasonably foreseeable loss or damage. You are also entitled to have the goods repaired or replaced if the goods fail to be of acceptable quality and the failure does not amount to a major failure. The benefits provided to you as the consumer by this warranty are in addition to other rights and remedies available to you under the law.

THE WARRANTY DOES NOT COVER:

- a. Any damage resulting from improper use
 - b. Faulty installation or modification made during installation
 - c. The cost of removing and reinstalling the product
 - d. Travel and /or other expenses due to customer's remote location
 - e. Transport charges and damage in transit. It is your responsibility to deliver and pick up your product, including any costs associated with the postage of your repair or replacement product. If you do freight your product we recommend that you insure against loss or damage.
 - f. Any loss directly or indirectly associated with the product failing to operate.
-

TO MAKE A CLAIM UNDER THIS WARRANTY PLEASE CALL

1800 88 39 64



OUTDOOR SUPACENTRE PTY LTD
2 Stanley St Silverwater NSW, 2128
PHONE: 1800 88 39 64
www.4wdsupacentre.com.au

